

Forces and Laws of Motion

Friction, Inclines and Multi-Body Problems

1. Compute the size of the initial upward acceleration of a rocket of mass 1.30×10^4 kg if the initial upward thrust of its engine is 2.60×10^5 N. Do not neglect the weight of the rocket. Construct the force diagram

2. A 60 kg woman stands in an elevator that is accelerating downward at 3.10 m/s^2 .

a) Construct the force diagram for the woman

b) What is her weight?

c) What is her apparent weight? (measured by the normal force acting on her)

d) The elevator now accelerates up at 3.10 m/s^2 . Construct the force diagram and determine the woman's apparent weight.

3. The maximum force that a grocery bag can withstand without ripping is 250 N. Suppose that bag is filled with 20.0 kg of groceries and lifted with an acceleration of 5.0 m/s^2 . Do the groceries stay in the bag?

4. A shuffleboard disk is accelerated to a velocity of 5.8 m/s and released. If the coefficient of kinetic friction between the disk and the concrete court is 0.31, how far does the disk go before it comes to a stop? The courts are 15.8 m long.

5. A 15.0 kg box is being pulled along level ground by a 75.0 N force that is directed at an angle of 20° above the horizontal. The coefficient of kinetic friction is 0.330. What is the acceleration of the box?



6. Anjali, who has a mass of 45 kg, starts down a slide that is inclined at an angle of 45° with the horizontal. If the coefficient of kinetic friction between Anjali's shorts and the slide is 0.25, what is her acceleration? Try to first derive an expression for a in terms of the given variables (θ , μ_k , g).

7. A 63-kg water skier is pulled at a constant speed up a 14.0° incline by a rope parallel to the incline with a tension of 311 N.

- a) What is the coefficient of kinetic friction between the skis and the incline?
 b) If the tension in the rope were increased to 511 N, determine the acceleration of the skier.

8. A block is set on an adjustable ramp and the angle of incline is increased slowly until the block is observed to start sliding when the angle is θ .
- a) Determine the coefficient of static friction, μ_s , in terms of the maximum angle of incline, θ , at which the block can remain at rest on the ramp.
 b) Considering the fact that μ_s is almost always less than or equal to one, at what amount of incline would there be too little friction to prevent virtually anything from sliding?

10. a) $m_1 = 5 \text{ kg}$ and $m_2 = 8 \text{ kg}$.

A block of mass m_1 is on a ramp that is inclined at 20° above the horizontal. It is connected by a string to a block of mass m_2 that hangs over the top edge of the ramp. The coefficient of kinetic friction between the incline and the m_1 block is 0.22. What is the acceleration of the masses and the tension in the string?

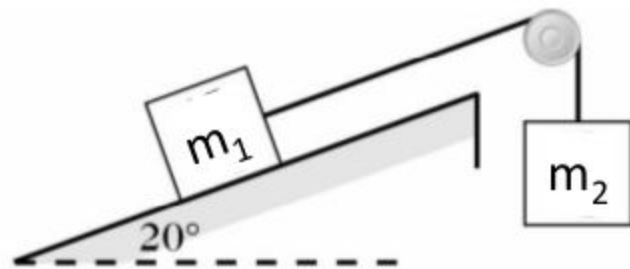

b) If $m_1 = 8 \text{ kg}$, and the coefficient of static friction between m_1 and the incline is 0.300, find the maximum value of m_2 slide up the incline (ie. when static friction is maximum).

11. In the diagram at right, m_2 has a mass of 20.0 kg. There is friction on the incline. Static friction can exert a maximum force of 30.0 N on m_2 . This friction can act up or down the incline, depending on the value of m_1 .

a) If m_1 is heavy enough, m_2 will start to accelerate up the

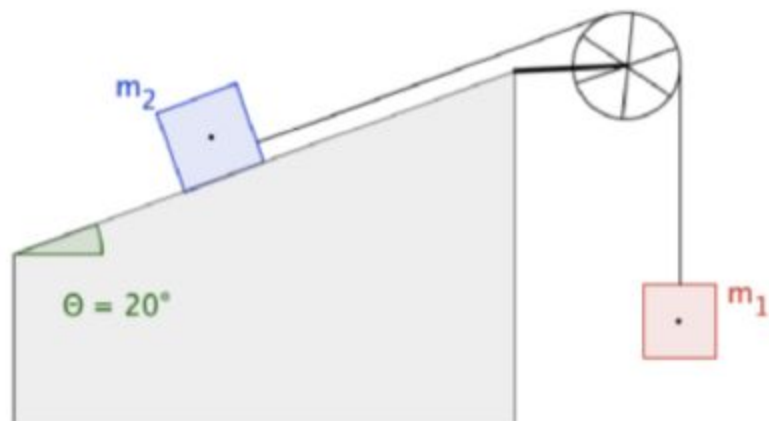

incline. What is the maximum value m_1 can have without m_2 sliding up the incline?

b) If m_1 is light enough, m_2 will start to accelerate down the incline. What is the minimum value m_1 can have without m_2 sliding down the incline. (static friction is not in the same direction as part a))

12. If mass #1 = 2 kg, mass #2 = 4 kg, and mass #3 = 6 kg, find the acceleration of the three masses, and the tension in each string. The pulleys are frictionless, but the coefficient of kinetic friction between the plane and block 2 is 0.400.

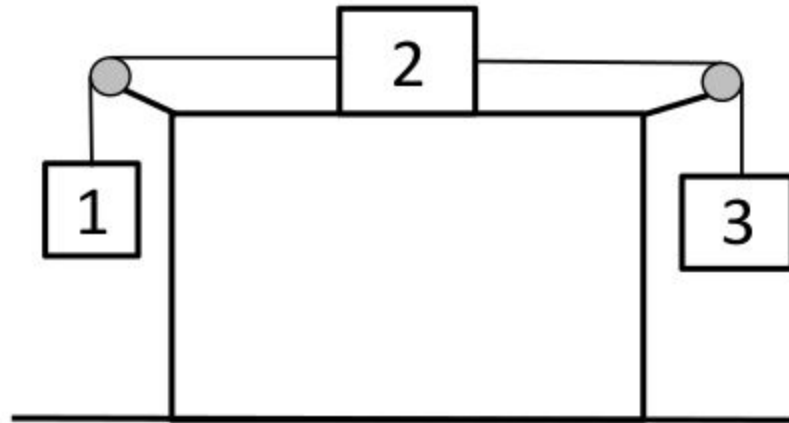

13. If both masses equal 3 kg, find the acceleration of the two masses, and the tension in the string.

The 40° incline is frictionless, but the 20° incline has a coefficient of kinetic friction of 0.100.

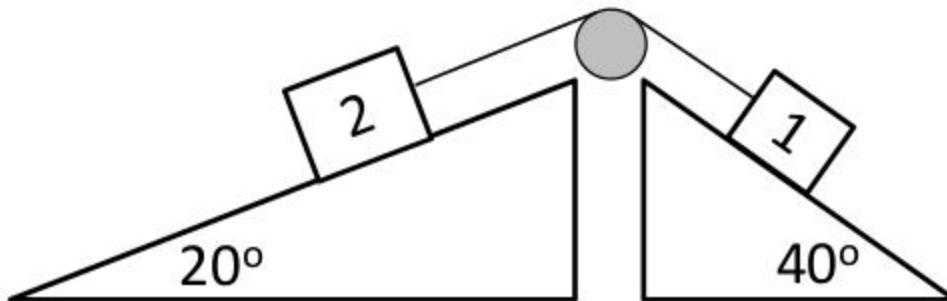

14. In the figure to the right, two boxes of masses $2m$ and $5m$ are in contact with each other on a frictionless surface. A force, F , is applied to $2m$. Answers to the following questions should be in terms of F and m

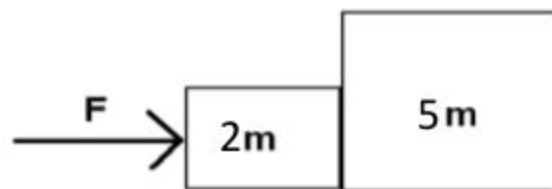

- a) What is the acceleration of the more massive box?
- b) What is the force causing the acceleration of the more massive box (the net force on $5m$?)
- c) What is the force exerted on the smaller box by the larger box?
- d) What is the net force on the smaller box?
- e) Show all the action reaction pairs of forces for all the forces acting on the boxes.
- f) Answer parts a)-d) if there is friction between the blocks and the table and the coefficient of kinetic friction is μ_k . Answers should be in terms of F , m , μ_k and g

15. This arrangement is being pulled across the floor. The coefficient of kinetic friction between the larger block and the floor is (0.50). The coefficient of static friction between the two blocks is (0.75). (Note that the weight, not the mass, of each block is given)

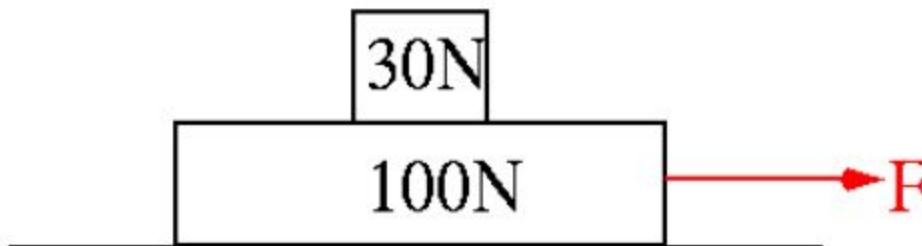

- a) What is the maximum acceleration of the blocks before the top block begins to slide off the bottom block? (Hint: Draw the free body diagram of the top block and determine the acceleration when the coefficient of static friction is at its max value of 0.75 and the top block is at rest relative to the bottom block)
- b) What is the maximum horizontal Force, F , that can be exerted on the lower block before the top block begins to slide off? (Hint: Draw the free body diagram of the bottom block and apply Newtons 2nd law to the bottom block)

16. A system of two blocks is accelerated by an applied force of magnitude F on a frictionless horizontal surface.



- a) What is the acceleration of the blocks in terms of m and F ?

- b) What is the tension in the string between the blocks in terms of F ?
- c) If $m = 3 \text{ kg}$ and the applied force were 48 N , what is the acceleration of the blocks?
- d) What is the tension in the string between the blocks?

17. Two blocks of mass $m_1 = 2 \text{ kg}$ and mass $m_2 = 7 \text{ kg}$ are wedged up against one another and against a wall by a horizontal force F . Do each section algebraically before putting in numbers:

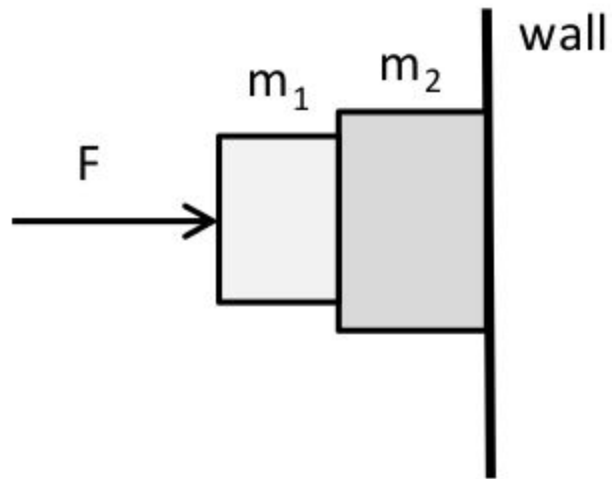

a) What is the coefficient of static friction between m_1 and m_2 (call this μ_{s1}) and between m_2 and the wall (call this μ_{s2}) if the MINIMUM force F_{\min} required to keep the blocks from breaking loose and sliding under the influence of gravity is $F_{\min} = 25 \text{ N}$?

- b) The force F is decreased to 20 N . The blocks break loose and begin to fall. If the coefficient of kinetic friction between m_1 and m_2 AND between m_2 and the wall are $\mu_{k1} = .15$ and $\mu_{k2} = 0.9$ respectively, what are the accelerations of m_1 and m_2 ? Note that they will not be the same.
- c) Why are the accelerations different?

18. (Very Challenging)
A man drags a 100 kg crate up the ramp of a truck. The ramp is inclined at 20° and the man pulls at an angle of 30° above the ramp. The coefficient of friction between the crate and the ramp is 0.2 .

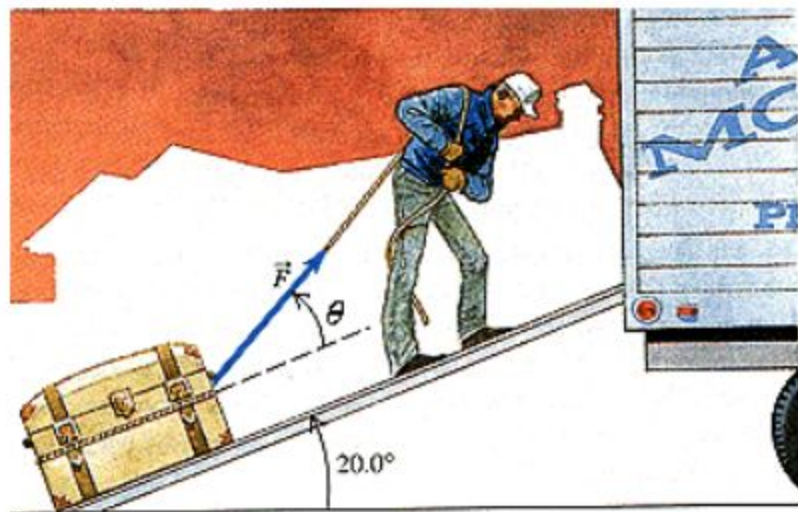

- a) What is the normal force on the crate in terms of the applied force, F ? (Hint: The normal force does not just balance the perpendicular component of gravity)

b) What is the minimum force the man would have to apply to pull the crate up the ramp (Hint: minimum force would be the force required to pull the crate up the ramp at constant velocity)

Answers

1. a = 10.2 m/s^2 up 2b) 588 N c) 402 N d) 774 N 3. NO, $F_T = 296 \text{ N}$ 4. 5.5 m 5. 2.03 m/s^2
6. 5.2 m/s^2 7a) 0.27 b) 3.17 m/s^2 up the incline 8a) $\mu_s = \tan\theta$ b) 90°
9a) $a = 4.2 \text{ m/s}^2$, $F_T = 28 \text{ N}$ b) 0.976s 10. $a = 3.96 \text{ m/s}^2$ down, $F_T = 46.7 \text{ N}$ b) 5.0 kg
11. a) 9.90kg b) 3.78 kg 12. $a = 1.96 \text{ m/s}^2$; $T_{\text{left}} = 23.5 \text{ N}$; $T_{\text{right}} = 47.0 \text{ N}$ 13. $A = 1.01 \text{ m/s}^2$, $F_T = 15.9 \text{ N}$
14. a) $F/7m$ b) $5/7 F$ c) $-5/7 F$ d) $2/7 F$ f) $a = 3.03 \text{ m/s}^2$, $F_{\text{net on } 4m} = 24.3 \text{ N}$, -40 N , $F_{\text{net on } m} = 6.08 \text{ N}$
15. a) 7.35 m/s^2 b) 162 N
16. a) $F/4m$ b) $F/4$ c) 4 m/s^2 d) 12 N
17. a) $\mu_s 1 = 0.784$, $\mu_s 2 = 3.5$ b) $a_1 = 8.3 \text{ m/s}^2$, $a_2 = 7.7 \text{ m/s}^2$
c) The coefficient and force of kinetic friction acting on each of the blocks is different and this causes the acceleration of each block to be different
18. $F_N = 921 - 0.5F$ b) 538N